

J-1160 Jaw Crusher



SPECIFICATION:

Inlet Opening:	1000 (40") x 660mm (26")
Net Engine Power:	224kW 300HP
Portability:	Tracked
Operating Weight:	33,500kg (73,854lbs) (without by-pass conveyor and magnet options) 36,000kg (79,365 lbs) (with by-pass conveyor and magnet options)

WORKS FOR YOU.™

SPECIFICATION

JAW CHAMBER

Jaques 2440 Chamber

1000mm (40") x 660mm (26") Inlet opening

Hydrostatic drive

Full hydraulic CSS adjust + drawback bar

Reverse operation for clearing blockages

The standard liner profile is the S-Tooth.

CSS opening range- 40mm (1.5") to 135mm (5 1/2")

MAIN CONVEYOR

900mm (36") Belt

Discharge height- 3300mm (10' 10")

High spec scraper at head drum

Overband magnet option

Dust suppression- main conveyor fitted with hose and spraybars as standard (no pump supplied)

Low level greasing standard

Impact bars at feed point

Wear resistant liners at crusher feed point

HOPPER AND FEEDER

5m³ (6.5 yd³) capacity- 8m³ (10.4 yd³) capacity with hopper extensions*

10mm Wear resistant side walls

Selectable discharge to dirt conveyor or main conveyor

Grizzly feeder with integral screen

*Hopper extensions are optional -Hydraulic folding as standard

POWERPACK AND CONTROL SYSTEM

Tier 3/Stage 3A: Caterpillar C9 224kW (300hp)

Tier 4i/Stage 3B: Scania DC9 70A 202kW (275hp)

Hydrostatic drive

Advanced electronic control system, with simple operation and diagnostic modes (CANBUS)

UNDERCARRIAGE

Bolt on tracks

400mm (16") shoe

3280mm (10' 9") Sprocket centres

Single tracking speed with 'soft start'

MAGNETIC SEPARATOR (OPTIONAL)

Suspended self cleaning crossbelt overband magnet

750mm (30") belt

Centres 1590mm (62")

TOOL BOX

Mounted lockable toolbox

Tool Kit and flogging spanners

Grease gun

Manuals

REMOTE CONTROL UNIT (OPTION)

Full function radio remote unit

Full function radio remote unit (Option)

Machine can be switched from crushing mode into trackmode, moved, and switched back to operating mode from remote control unit.

Umbilical control unit (supplied standard) Offers track control only

CONTROL SYSTEM

Advanced CANBUS compliant system Large display screen(IP67 Rated)

Five simple operating modes with menu driven graphic user interface:

- Track mode: For moving machine
- Manual mode: For manually starting machine
- Automatic mode: For automatically starting the machine in predetermined sequence
- Configuration mode: For testing/setting individual components
- Language selection: For setting languages

Choice of preset parameters to suit crushing applications

- Hard Rock
- Soft Rock
- Demolition and Recycle

User friendly incremental selection of feeder and crusher speed enable the operator to achieve the optimal throughput.

Detachable doglead control for tracking

Radio remote control (option)

Integrated machine and engine control panel.

Lockable compartment

Auto regulating feeder selectable for improved throughput control.

BYPASS CONVEYOR (OPTIONAL)

650mm (26") Plain belt

Universal mounting to left or right hand side- (Specify at time of order)

Hydraulic folding for transport

Low level greasing

2000mm (6' 8") Discharge height

Optional 2800mm (9' 2") discharge height conveyor

TANK CAPACITIES

Hydraulic Tank Capacity: 530 litres/117UK gal/140 US gal

Fuel Tank Capacity: 400 litres/88UK gal/106 US gal

STANDARD FEATURES

ENGINE:

Tier 3 / Stage 3A Caterpillar C9 Acert 224 kW (300hp) water cooled diesel engine

Tier 4i / Stage 3B Scania DC9 70A 202kW (275hp) water cooled diesel engine

JAW CHAMBER:

Jaques 1000 x 660mm (40" x 26") single toggle jaw crusher

Hydrostatic drive and advanced electronic control system

Fully hydraulically adjustable closed side setting

Reversible operation for clearing blockages

S tooth liners - 18% Manganese as Standard

HOPPER/ FEEDER:

5m³ hopper (6.5yd³)

Heavy duty vibrating feeder

Grizzly feeder with integral pre-screen, standard 50mm spacing

Selectable discharge to by-pass conveyor or main conveyor

Mesh aperture on grizzly feeder: 30mm

MAIN CONVEYOR:

900mm wide main belt fitted with impact bars at feed point

High spec scraper at head drum

Piped for dust suppression complete with spraybars

GENERAL:

Piped for overband magnet

Galvanised catwalk c/w handrail, kick board and access ladders

Heavy duty undercarriage unit with 400mm wide pads

Handheld track control set with connection lead

Single speed tracks with 'soft start'

Safety guards in compliance with machinery directive

Emergency stops

OPTIONAL EQUIPMENT

Radio remote System: Operational controls of machine (auto start/ stop) & track movement

Bypass conveyor with 650mm wide plain belt

Extended bypass conveyor with 650mm wide plain belt

Over band magnet c/w stainless steel skirting & stainless steel discharge chute

Beltweigher

1 nr stockpiler drive (requires 1 aux drive)¹

Hydraulic folding hopper extensions - total capacity 8m³ (10.4yd³)

Special paint colour (if different from Terex White RAL 1013 or Finlay Orange RAL 2002). RAL must be specified

Optional spacing on grizzly - 75mm

Hydraulically driven water pump (requires 1 aux drive)¹

Re-bar deflector plate - fits underneath jaw

Dust cover on discharge conveyor

Rip stop belt option (check leadtime)

Lighting mast

Cold climate lubrication kit (for below -10°C ambient)

Hot climate lubrication kit (For above +30°C ambient)

Hot climate cooler pack (For above +40°C ambient). Note Includes hot climate lubrication kit

Separate Operators Panel

Please contact the sales department for jaw liner options (Depending on application)

*Note: ¹ Only 2 aux drives available on any 1 machine

WORKS FOR YOU.™

J-1160

TRANSPORT AND WORKING DIMENSIONS

TRANSPORT

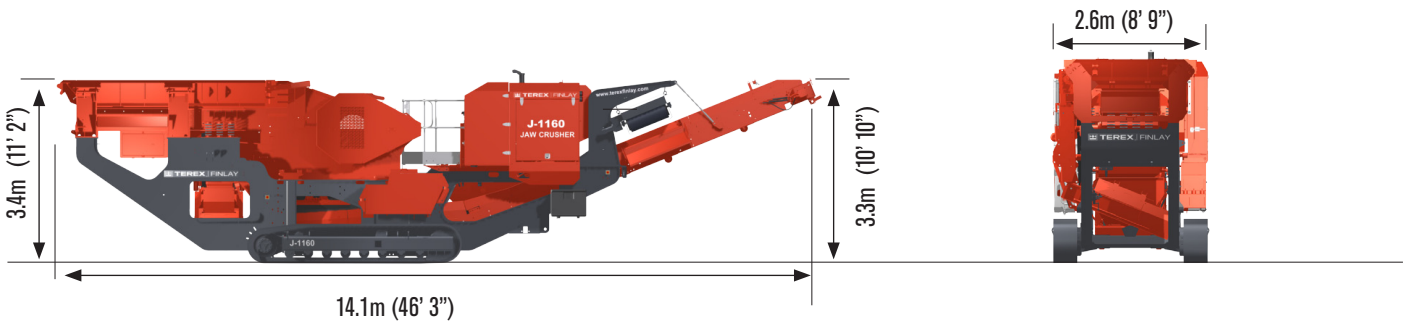

WORKING

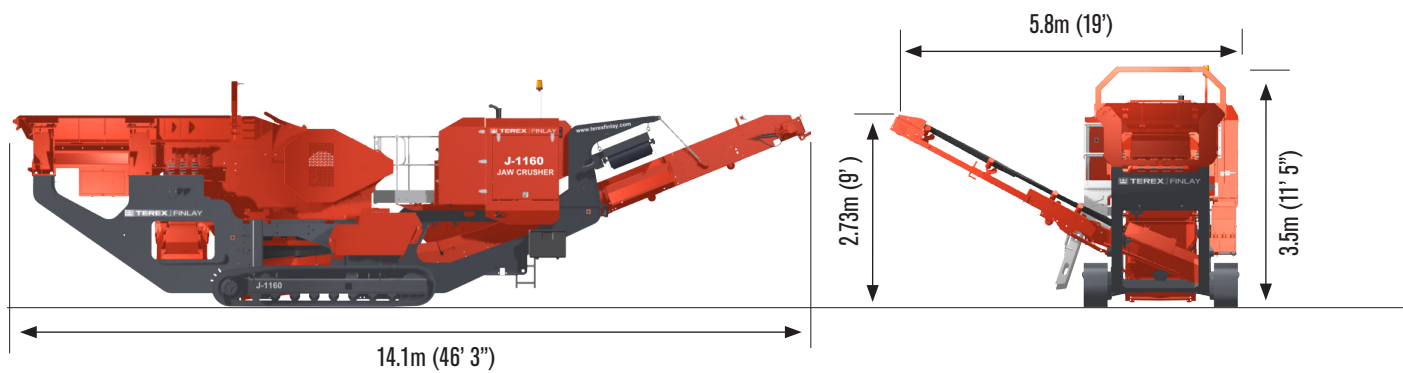

WEIGHT: 33,500kg (73,854lbs)

Operating weight (without By-pass conveyor and magnet options)